



Gimbal with mounting bracket – The highly diverse special tool

**Versatile lighting technology
with cardanic suspension, optimised
for mounting in channels**

The principle of cardanic suspension with Gimbal recessed spotlights translates into an especially precise, comfortable swivel mechanism. This is not only more compact than standard versions, but the centre of the luminaire head maintains its position during alignment – as a result Gimbal is ideal for lighting concepts with ceiling channels. The luminaire can also be simply installed in on-site ceiling channels thanks to its special mounting bracket. Several

sizes and wattages for any light distribution allow for flexible lighting concepts. Applications consist of retail projects, hotels and restaurants as well as buildings where lighting designers plan discreet and effective lighting from ceiling channels or coves.

Gimbal with mounting bracket Recessed spotlights



Structure and characteristics

The features described here are typical of products in this range. Special versions may offer additional or varying features. A comprehensive description of the features of individual products can be found on our website.

1 ERCO Spherulite lens

- Light distributions: narrow spot, spot, flood, wide flood, extra wide flood, oval flood or wallwash
- Oval flood 360° rotation

2 ERCO LED-module

- High-power LEDs: warm white (2700K or 3000K) or neutral white (3500K or 4000K)
- Collimating lens made of optical polymer

3 Luminaire

- Black
- Cast aluminium, powder-coated
- Gimbal suspension: polymer
- Pivotal through 0°-40°, pivotable through 60° in the longitudinal direction of the channel
- Mounting bracket: steel, powder-coated

4 Control gear

- Switchable, phase dimmable, DALI dimmable or Casambi Bluetooth
- Phase dimmable version: Dimming with external dimmers possible (trailing edge)

Variants on request

- Connection: 3- or 5-pole plug with connection cable (Wago or Wieland)
 - Housing: 10,000 further colours
- Please contact your ERCO consultant.



Design and application:
www.erco.com/gimbal-cc

Gimbal with mounting bracket Recessed spotlights



Oval flood freely rotatable
The oval flood Spherolit lens can be freely rotated with round luminaire heads to optimally match the lighting to various objects.



Cardanic suspension
Especially with high ceilings, small swivel movements have a strong effect on the position of the light beam - cardanic suspension facilitates precise luminaire alignment in such cases.

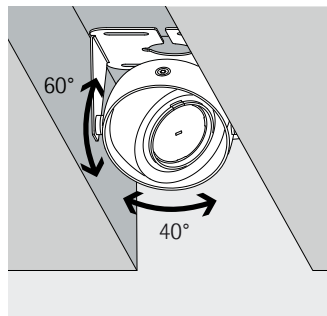

Ideal for ceiling channels
The compact design and central pivot point predestine some luminaires for installation in ceiling channels.

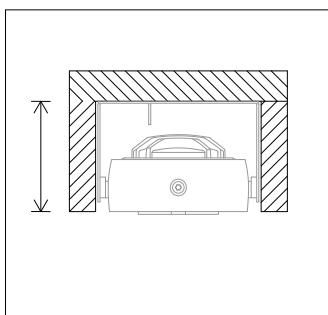

Shallow recess depth
In compact installation situations, every millimetre is decisive with the recess depth of a luminaire. ERCO has thus developed special luminaires for shallow recess depths that guarantee very good quality of light even in very tight installation conditions.

Special characteristics



Oval flood, freely rotatable



Gimbal suspension



Ideal for ceiling channels



Shallow recess depth



ERCO high-power LEDs



Efficient Spherolit technology



Different light distributions



Different light colours



Excellent thermal management



EMC-optimised



Various construction sizes



Pivotable through 40°



Accessory for maximum visual comfort



Switchable



Phase dimmable



DALI dimmable



Casambi Bluetooth

Gimbal with mounting bracket Recessed spotlights – Luminaire arrangement

Recessed spotlights
Narrow spot, Spot, Flood

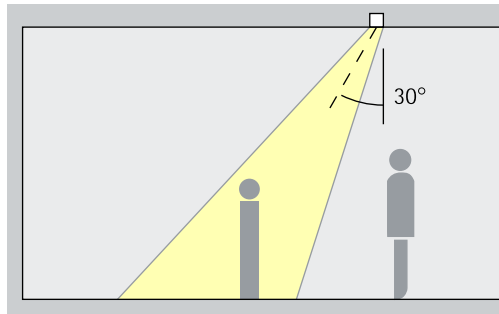

Accentuation
Gimbal spotlights for ceiling channels accentuate products and architectural details effectively. The ideal angle of tilt (α) for this is around 30°. The object is modelled without distorting the effect as a result of excessive shadowing. It also prevents shadows cast by the observer.

Arrangement: $\alpha = 30^\circ$

Recessed floodlights
Wide flood, Extra wide flood, Oval flood

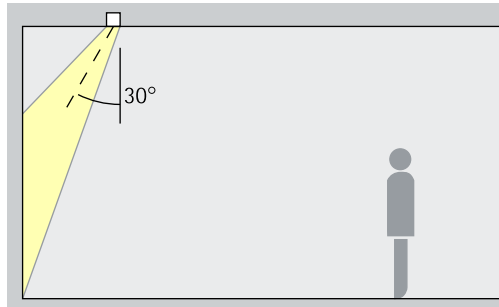

Washlighting
The ideal angle of tilt (α) for floodlighting objects with a long, square shape, e.g. tables or merchandise displays, is around 30°.

Arrangement: $\alpha = 30^\circ$

Recessed lens wallwashers
Wallwash

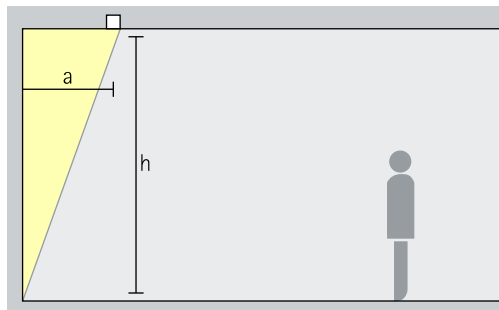

Wallwashing
For uniform vertical illuminance, the distance (a) of Gimbal lens wallwashers from the wall should be around one third of the wall height (h). This results in an angle of tilt (a) of approx. 35°.

Arrangement: $a = 1/3 \times h$ bzw. $\alpha = 35^\circ$

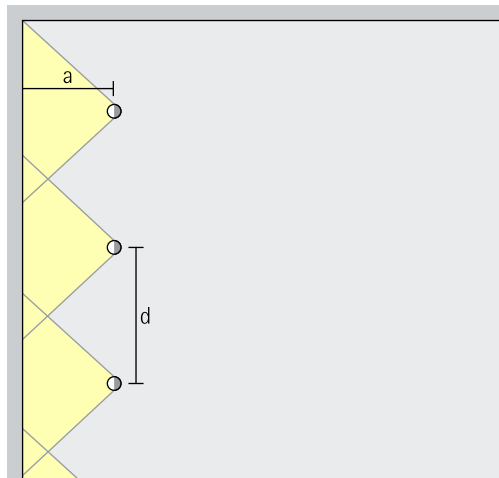

For good longitudinal uniformity, the spacing (d) of Gimbal lens wallwashers may be up to 1.2 times the offset from the wall (a).

Arrangement: $d \leq 1.2 \times a$

Optimal wall offset and luminaire spacing values are indicated in the wallwasher tables on the product data sheets.

Gimbal Installation information

Recessed spotlights

The mounting bracket for Gimbal recessed spotlights and recessed floodlights enables diverse installation options. The luminaire is predestined for mounting in ceilings, e.g. suspended ceilings, in ceiling channels or in slab ceilings. Alternatively, the mounting bracket can also be fixed horizontally or vertically to other surfaces of the building. Cardanic suspension ensures that Gimbal can be flexibly aligned.

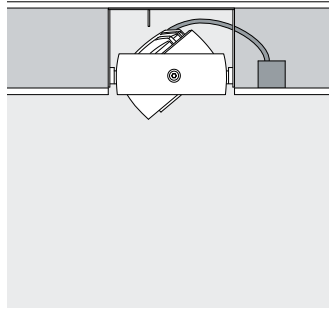

Installation: Suspended ceiling

A ceiling cutout can be quickly and efficiently implemented in suspended ceilings for the flush-mounting of Gimbal recessed spotlights.

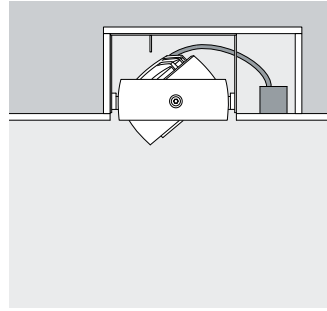

Installation: Ceiling channel

To avoid any view into the ceiling cavity on the side, the ceiling channel can be closed laterally – either directly or with a side pocket for cable routing and control gear.

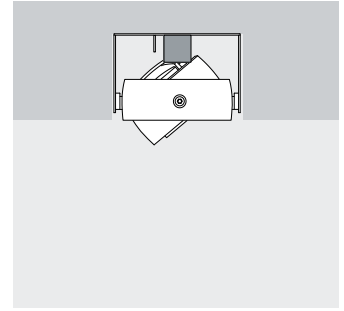

Installation: Ceiling slab

If cutouts are intended for the shell construction the Gimbal recessed spotlight can also be integrated into ceiling slabs.

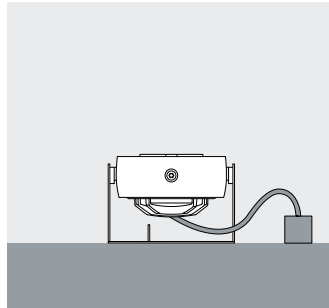

Alternative installation options

The mounting bracket allows Gimbal to be installed not only in the ceiling channel, but also on horizontal surfaces, such as beams or ledges.

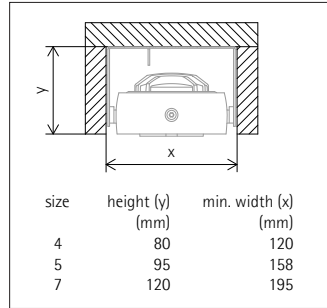

Dimensioning of the ceiling channel

The minimum width of the ceiling channel corresponds to the width of the mounting bracket. The depth is according to the luminaire size and

the issue of whether the swivelled luminaire should be allowed to protrude from the ceiling.

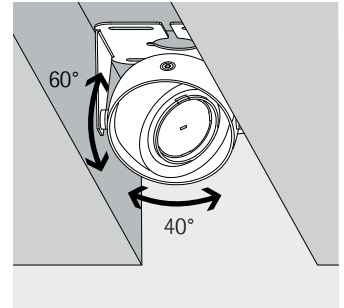

40° tiltable

Gimbal can be tilted through 40°. In the longitudinal direction of the channel the luminaire can be tilted up to 60°.

Control gear

Gimbal recessed spotlights have control gear that can be flexibly accommodated in the ceiling cavity. Cable lengths and any minimum distances between the control gear and luminaire head are specified on the product data sheet.

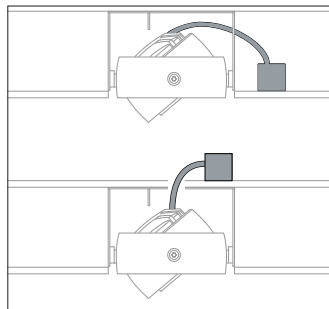

Position of control gear

The control gear can be positioned either to the side or above the ceiling channel.

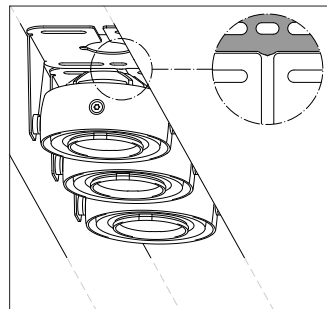

Sequential arrangement possible

The mounting brackets also enable sequentially installing Gimbal. The control gear is positioned either to the side or above here as well.

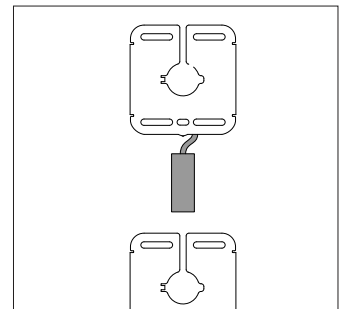

Control gear between luminaires

With sequential arrangements the control gear can also be installed between the luminaires.

Gimbal with mounting bracket Recessed spotlights

Construction size

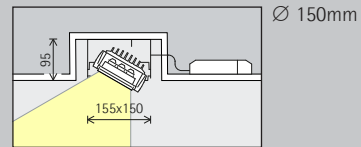
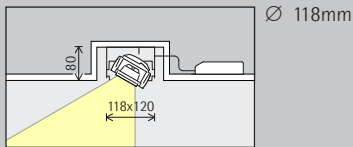

LED module
Maximum value at 4000K CRI 82

6.1W/786lm	2W/262lm (Narrow spot)
9.3W/1107lm	3.1W/369lm (Narrow spot)

12.1W/1572lm	4W/525lm (Narrow spot)
18.6W/2213lm	6.2W/738lm (Narrow spot)

Light colour

	2700K CRI 92		3500K CRI 92
	3000K CRI 92		4000K CRI 82
	3000K CRI 97		4000K CRI 92

	2700K CRI 92		3500K CRI 92
	3000K CRI 92		4000K CRI 82
	3000K CRI 97		4000K CRI 92

Light distribution

Recessed spotlights	Recessed floodlights
Narrow spot	Wide flood
Spot	Extra wide flood
Flood	Oval flood
Recessed lens wallwashers	
Wallwash	

Recessed spotlights	Recessed floodlights
Narrow spot	Wide flood
Spot	Extra wide flood
Flood	Oval flood
Recessed lens wallwashers	
Wallwash	

Control

	Switchable		DALI
	Phase dimmable		Casambi Bluetooth

	Switchable		DALI
	Phase dimmable		Casambi Bluetooth

Colour (housing)

	Black
	10,000 colours *





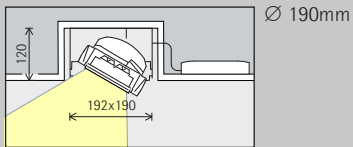

	Black
	10,000 colours *







Accessories





	Lenses		Cross-baffle
	Snoot		Honeycomb anti-glare screen





2.3W/3144lm	8.1W/1048lm (Narrow spot)
37.3W/4427lm	12.4W/1476lm (Narrow spot)

	2700K CRI 92		3500K CRI 92
	3000K CRI 92		4000K CRI 82
	3000K CRI 97		4000K CRI 92

Recessed spotlights	Recessed floodlights
 Narrow spot	 Wide flood
 Spot	 Extra wide flood
 Flood	 Oval flood
Recessed lens wallwashers	
 Wallwash	

 Switchable	 DALI
 Phase dimmable	 Casambi Bluetooth

	Black
	10,000 colours *

* available on request

Article numbers and planning data:
www.erco.com/016770

Design and application:
www.erco.com/gimbal-cc





Prada store, Milan.
Photography:
Frieder Blickle,
Hamburg.